

HAVA DAMPERLERİ DTH-01 DTH-02 (AIR DAMPERS)



DTH-01

Dikdörtgen Hava Damperi



DTH-02

Yuvarlak Hava Damperi

Kullanım Yeri

Havalandırma sistemlerinde kanal hava miktarını ayarlamak için kullanılır. İsteğe bağlı olarak servo motor ilavesi yapılabilir. Kanatlar arasında kauçuk sızdırmazlık contası bulunur. Kanatlar aerodinamik yapıya sahip olduğundan direnç oluşturmazlar.

Montaj

Hava damper kasası kendinden flaşlı olduğunda kanala kolayca montaj yapılabilir.

Descripton

Dampers are used to regulate air quantity at grilles. Also motor can be added upon request. The blades have rubber gasket on the edges for less leakage. The blades have aerodynamically shaped for little resistance.

Surface Covering

The damper body is shelf flanged to installation easily.

MAFSALLI HAVA DAMPERİ

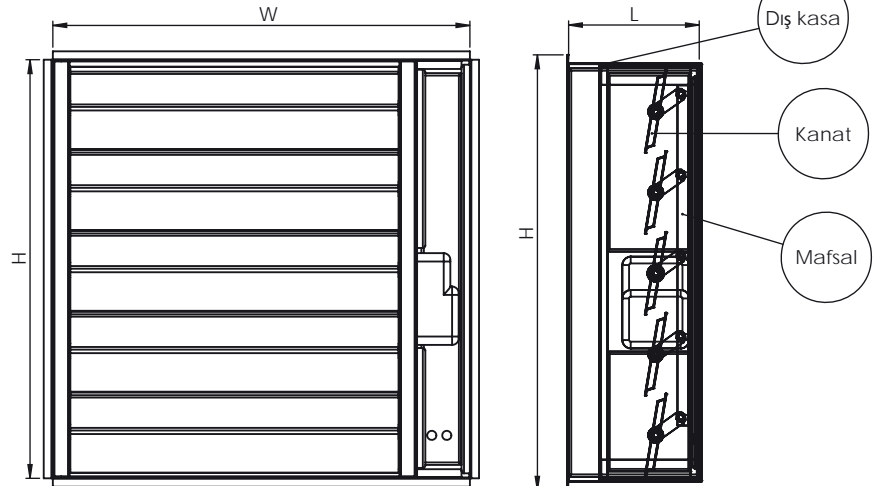
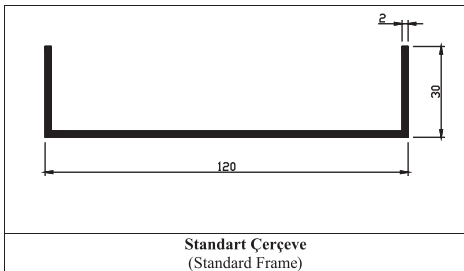

DİKDÖRTGEN HAVA DAMPERLERİ DTH-01 (RECTANGULAR AIR DAMPERS)

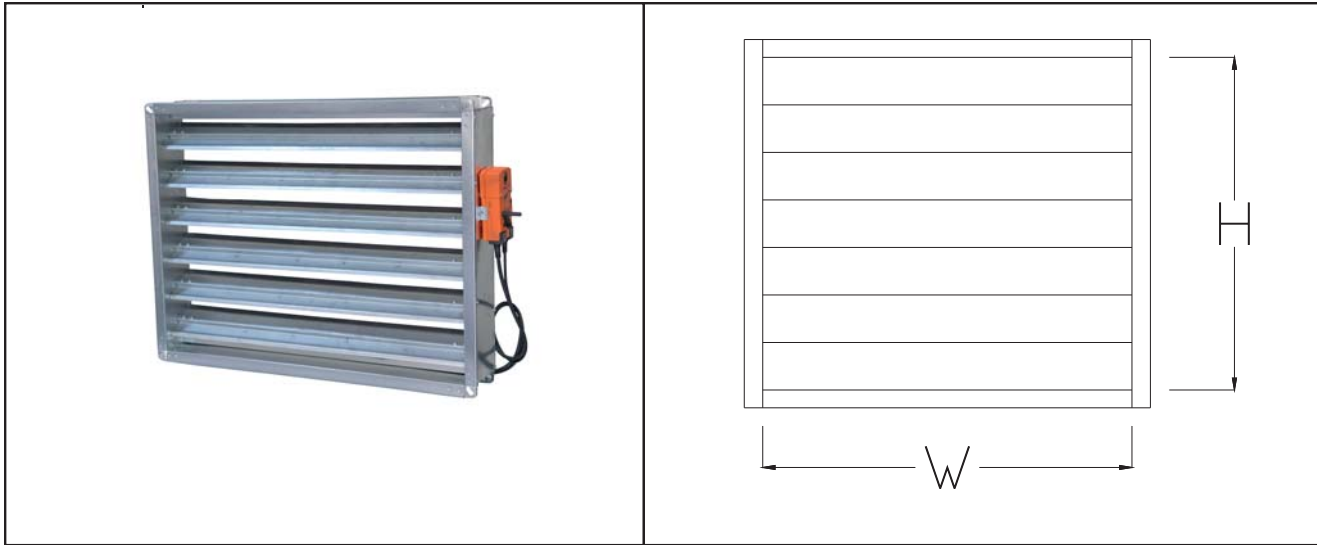

DİKDÖRTGEN HAVA DAMPERLERİ İÇİN STANDART ÖLÇÜLER – DTHDD (STANDART SIZES FOR RECTANGULAR AIR DAMPERS)

W	100 – 200 – 300 – 400 – 500 – 600 – 700 – 800 – 900 – 1000 – 1100 – 1200 – 1300 – 1400 – 1500
H	100 – 200 – 300 – 400 – 500 – 600 – 700 – 800 – 900 – 1000

YUVARLAK HAVA DAMPERLERİ DTH-01 (ROUND AIR DAMPERS)

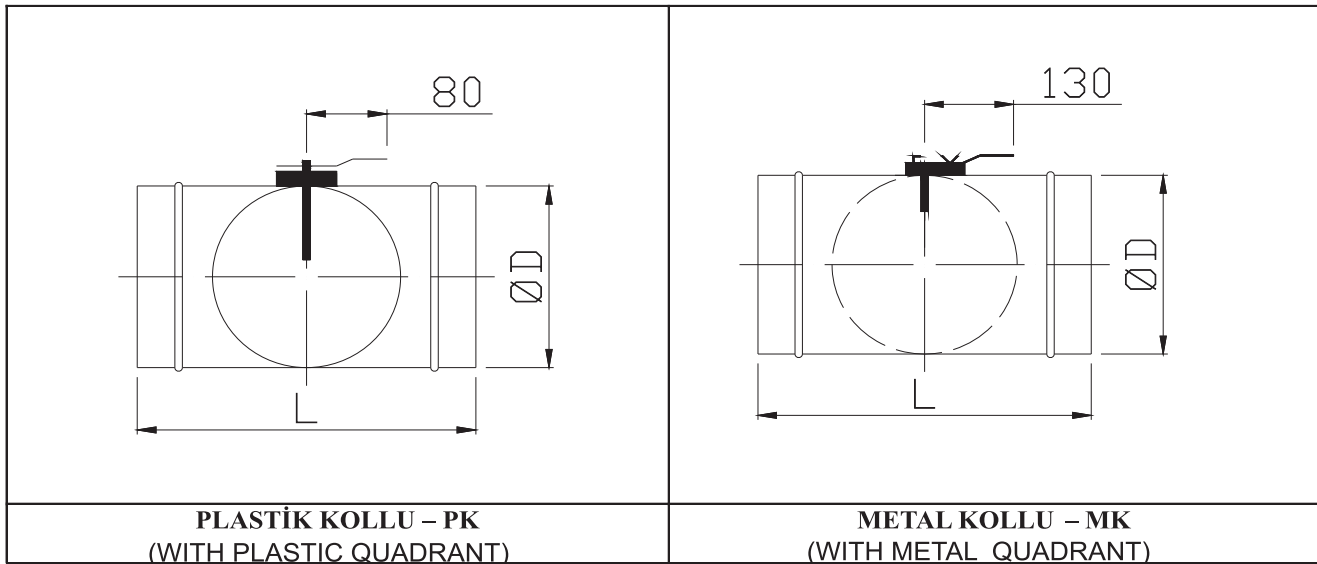

PLASTİK KOLLU – PK
(WITH PLASTIC QUADRANT)

METAL KOLLU – MK
(WITH METAL QUADRANT)

DAMPER KUMANDASI

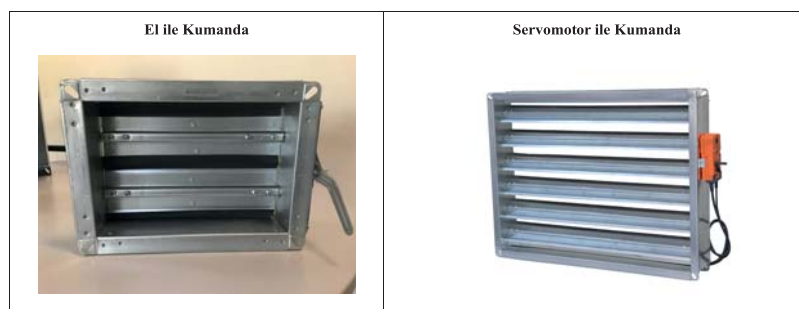

Damperlerin standart kumanda şekli el iledir. Hem el hem de motor kumandasına uygun olarak da temin edilebilir.